

Werkzeugkatalog

tool catalogue

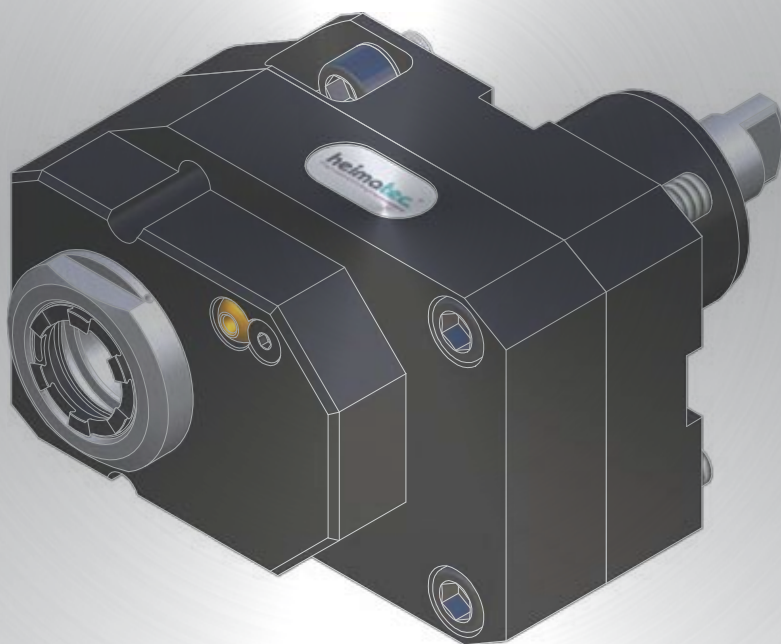

Mori Seiki

NL/NLX 1500 MC/Y/SMC/SY
NL/NLX 2000 MC/Y/SMC/SY
NL/NLX 2500 MC/Y/SMC/SY
NL/NLX 3000 MC/Y/SMC/SY



Hinweis zu den AGBs:

Diese finden Sie in unserem Internetauftritt unter

www.heimatec.de

Home/Impressum/AGB

Terms and conditions:

You will find them on our website

www.heimatec.com

Home/Imprint/Terms and Conditions

Das Katalog-Werk einschließlich aller seiner Teile ist urheberrechtlich geschützt. Jede Verwertung außerhalb der engen Grenzen des Urheberrechtsgesetzes ist ohne Zustimmung der Rechteeinhaber unzulässig und strafbar. Das gilt insbesondere für Vervielfältigungen, Übersetzungen, Mikroverfilmungen und die Einspeicherung und Verarbeitung in elektronischen Systemen.

heimatec® GmbH behält sich Änderungen technischer Art jederzeit ohne Vorankündigung vor. Dies gilt insbesondere bei Anpassungen an neue oder geänderte internationale Normen oder bei Weiterentwicklungen unserer Produkte oder Herstellungsprozesse.

This catalogue, including all its parts, is protected by copyright. Each use outside the restricted limitations of the Copyright Act is inadmissible and liable to prosecution without the consent of heimatec. This is particularly valid for duplication, translation, microfilming and feeding and processing in electronic systems.

heimatec® GmbH reserves the right of technical changes everytime without advance notice, which is particularly valid for adaptations to new or changed international standards, or to developments of our products or manufacturing processes.

angetriebene Werkzeuge driven tools



Axial-Bohr- und Fräskopf
axial drilling and milling head

$n_{max} = 6000 \text{ min}^{-1}$

8 010 66 062	ER 32 AX u-tec	EK	1:1
8 010 66 064	ER 32 AX u-tec	IK 25 bar	1:1
8 010 66 063	ER 32 AX u-tec	IK 70 bar	1:1
8 010 67 020	ER 40	EK	1:1
8 010 67 021	ER 40	IK 25 bar	1:1
8 010 67 022	ER 40	IK 70 bar	1:1
8 010 68 011	easy-quick HT 6	EK	1:1
8 010 68 012	easy-quick HT 6	IK 25 bar	1:1
8 010 68 013	easy-quick HT 6	IK 70 bar	1:1



Axial-Bohr- und Fräskopf
axial drilling and milling head

$n_{max} = 6000 \text{ min}^{-1}$

8 011 65 004	Kombidom/universal arbor 22	EK	1:1
8 011 66 005	Kombidom/universal arbor 27	EK	1:1
8 011 65 010	Kombidom/universal arbor 1"	EK	1:1
8 011 67 004	Kombidom/universal arbor 1 1/4"	EK	1:1



Axial-Bohr- und Fräskopf
axial drilling and milling head

Achsversatz / offset $A=50$

8 019 66 001	ER 32 AX u-tec	EK	1:1
$n_{max} = 6000 \text{ min}^{-1}$			
8 019 66 016	ER 32 AX u-tec	IK 140 bar	1:1
$n_{max} = 6000 \text{ min}^{-1}$			
8 019 66 007	ER 32 AX u-tec	EK	1:2
$n_{max} = 12000 \text{ min}^{-1}$			
8 019 66 002	ER 32 AX u-tec	IK 140 bar	1:2
$n_{max} = 12000 \text{ min}^{-1}$			

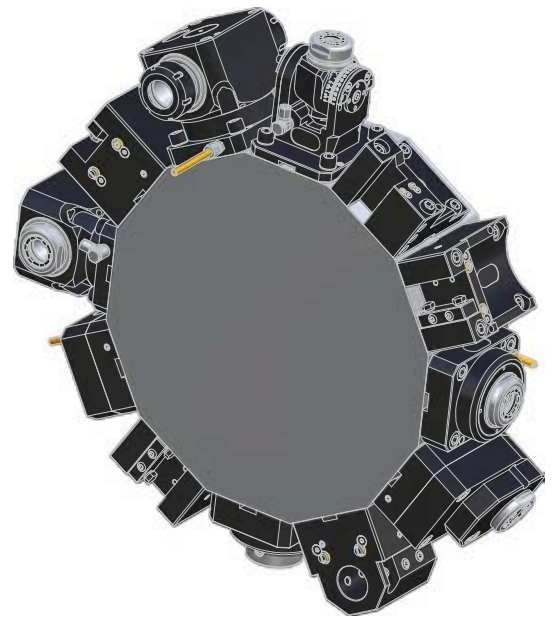

Winkel-Bohr- und Fräskopf
radial drilling and milling head

Mittenmaß / center distance $H=90$
 $n_{max} = 6000 \text{ min}^{-1}$

8 030 66 082	ER 32 AX u-tec	EK	1:1
8 030 66 083	ER 32 AX u-tec	IK 140 bar	1:1
8 030 65 041	ER 25 AX u-tec	EK	1:2
$n_{max} = 12000 \text{ min}^{-1}$			
8 030 65 042	ER 25 AX u-tec	IK 140 bar	1:2
$n_{max} = 12000 \text{ min}^{-1}$			
8 030 65 036	ER 25 AX u-tec	EK	1:3
$n_{max} = 18000 \text{ min}^{-1}$			
8 030 65 040	ER 25 AX u-tec	IK 140 bar	1:3
$n_{max} = 18000 \text{ min}^{-1}$			
8 030 67 031	ER 40	EK	1:1
8 030 67 032	ER 40	IK 140 bar	1:1
8 030 68 008	easy-quick HT 6	EK	1:1
8 030 68 009	easy-quick HT 6	IK 140 bar	1:1



Winkel-Bohr- und Fräskopf
radial drilling and milling head

Mittenmaß / center distance $H=90$
 $n_{max} = 6000 \text{ min}^{-1}$

8 031 65 012	Kombidom/universal arbor 22	EK	1:1
8 031 66 004	Kombidom/universal arbor 27	EK	1:1
8 031 66 005	Kombidom/universal arbor 1"	EK	1:1

Mori Seiki NL/NLX 1500/2000/2500/3000 MC/Y/SMC/SY



Winkel-Bohr- und Fräskopf radial drilling and milling head

doppelspindel / double spindle
Mittenmaß / center distance $H=90$
 $n_{max} = 6000 \text{ min}^{-1}$

8 039 66 022	ER 32 AX u-tec	EK	1:1
8 039 67 000	ER 40	EK	1:1
8 039 68 000	easy-quick HT 6	EK	1:1



Schwenkopf universal head

Mittenmaß / center distance $H=81$
 $n_{max} = 6000 \text{ min}^{-1}$

8 040 65 004	ER 25 AX u-tec	EK	1:1
8 040 65 008	ER 25 AX u-tec	IK 140 bar	1:1
8 040 64 011	ER 16 AX u-tec	EK	1:2
$n_{max} = 12000 \text{ min}^{-1}$			
8 040 64 016	ER 16 AX u-tec	IK 140 bar	1:2
$n_{max} = 12000 \text{ min}^{-1}$			



Winkel-Scheibenfräserkopf radial disk mill head

$\pm 30^\circ$ drehbar
 $\pm 30^\circ$ rotatable

Mittenmaß / center distance $H=100$
auf 0° absteckbar / 0° can be pinned
 $n_{max} = 3000 \text{ min}^{-1}$

8 037 64 006	$\varnothing 16$	EK	2:1
8 037 65 012	$\varnothing 22$	EK	2:1
8 037 66 004	$\varnothing 27$	EK	2:1
8 037 64 008	$\varnothing 3/4''$	EK	2:1
8 037 65 018	$\varnothing 1''$	EK	2:1



Mehrspindelbohrkopf multi spindle drilling head

Achsversatz / offset $A=\pm 35$
 $n_{max} = 6000 \text{ min}^{-1}$

8 050 65 000	ER 25 AX u-tec	EK	1:1
8 050 65 001	ER 25 AX u-tec	IK 25 bar	1:1



Mehrspindel-Winkelbohrkopf multi spindle radial head

Mittenmaß / center distance $H=90$
Achsversatz / offset $A=\pm 35$
 $n_{max} = 6000 \text{ min}^{-1}$

8 053 65 000	ER 25 AX u-tec	EK	1:1
8 053 65 001	ER 25 AX u-tec	IK 140 bar	1:1

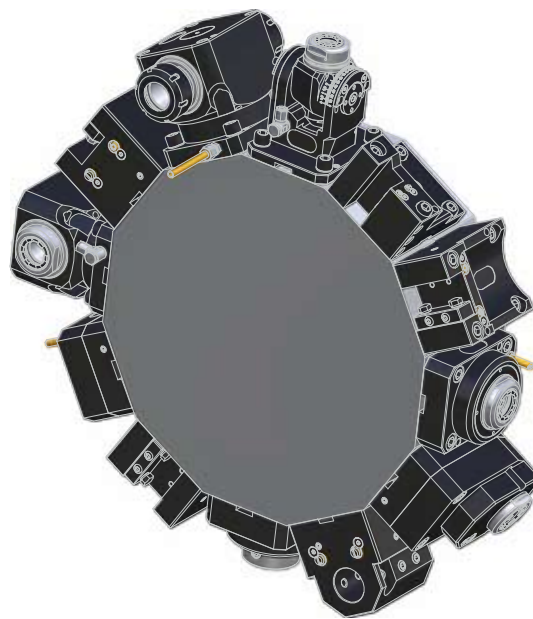

▶ Weitere Ausführungen auf Anfrage
further versions on request

▶ Zubehör **ZB...***
accessories **ZB...***

▶ **easy-quick**

▶ **u-tec**

feste Werkzeuge static tool holders



Kombi-Drehstahlhalter universal turning holder			
8 224 15 003	Vierkant/square 25		EK
8 224 15 014	Vierkant/square 1"		EK



Kombi-Doppel-Drehstahlhalter kurze Ausführung combi double turning holder short version			
8 251 15 001	Vierkant/square 25		EK
8 251 15 009	Vierkant/square 1"		EK

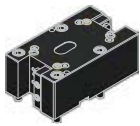

Kombi-Doppel-Drehstahlhalter lange Ausführung combi double turning holder long version			
8 251 15 002	Vierkant/square 25		EK
8 251 15 010	Vierkant/square 1"		EK



Kombi-Plandrehhalter combi facing holder			
8 244 15 001	Vierkant/square 25		EK
8 244 15 004	Vierkant/square 1"		EK



Bohrstangenhalter boring bar holder			
<i>Mittenmaß / center distance H=80</i>			
8 240 19 015	ø40		IK/EK
8 240 19 016	ø50		IK/EK
8 240 17 047	ø1"		IK/EK
8 240 18 036	ø1 1/4"		IK/EK
8 240 19 035	ø1 1/2"		IK/EK
8 240 19 050	ø2"		IK/EK



Doppel-Bohrstangenhalter double boring bar holder			
<i>Mittenmaß / center distance H=80/125</i>			
8 253 18 001	2x ø32		IK/EK
8 253 18 007	2x ø1 1/4"		IK/EK

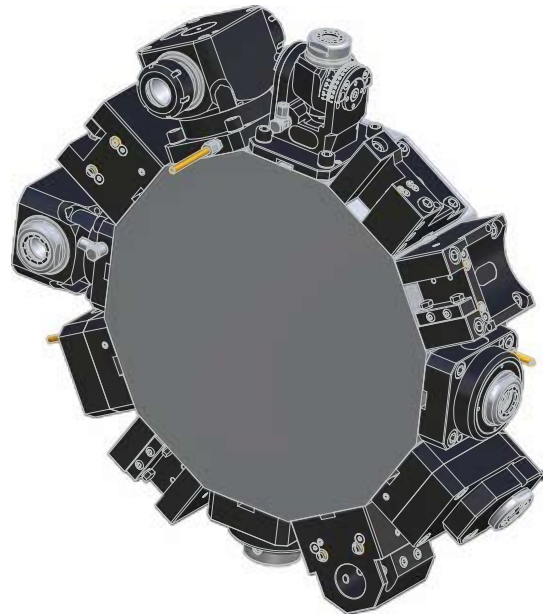

Abstechhalter cut-off holder			
8 224 12 007	Vierkant/square 25		EK
8 224 12 017	Vierkant/square 1"		EK

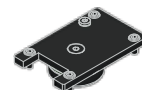

Abdeckplatte cover plate			
8 200 64 001			

Hauptsitz/headquarters

heimatec® GmbH
Präzisionswerkzeuge
Carl-Benz-Straße 4
D- 77871 Renchen
Postfach 11 36
D- 77867 Renchen
Tel.: +49 (78 43) 94 66 0
Fax: +49 (78 43) 94 66 66
www.heimatec.de
info@heimatec.de

heimatec® Inc.
16 E. Piper Lane Suite 121
USA- 60070 Prospect Heights IL
Tel.: +1 (847) 749 0633
Fax: +1 (847) 749 2445
www.heimatecinc.com
info@heimatecinc.com

heimatec® - Ost, JSC
ul. Kozjubinskogo 4 office 209
RUS- 121351 Moskau
Tel.: +7 (495) 648 69 19
Fax: +7 (495) 648 69 19
www.heimatec-ost.ru
sales@heimatec-ost.ru

